

## User Displays — Home owner

### General Operation

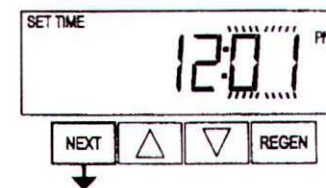
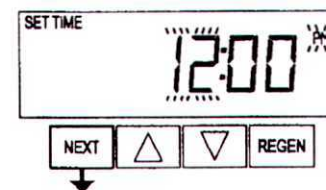
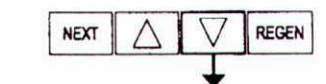
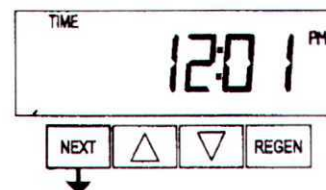
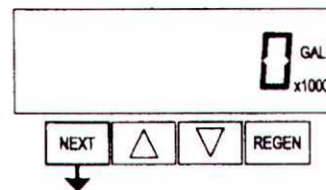
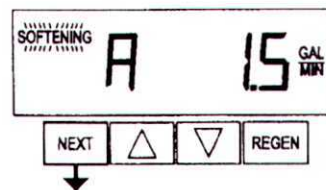
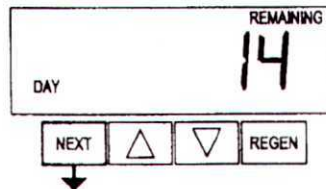
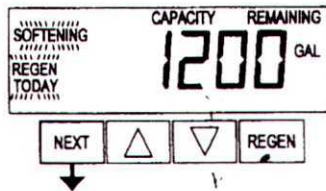

When the system is operating, one of five displays may be shown. Pressing NEXT will alternate between the displays shown below.

#### User 1

Typical user display. Shows volume remaining to regeneration. This screen will not be viewed if the control is set for time-clock operation.

#### User 2

Displays number of days to next regeneration.

#### User 3

Flow Rate.

Displays present flow rate.

Not viewed (along with SOFTENING or FILTERING Icon) if ALT A or ALT b is set in CONFIGURATION 4 and the valve is currently in Standby. When 1.0Γ is set in CONFIGURATION 1, the display will indicate the tank currently in Service ("A" or "b") in the leftmost digit.

#### User 4

Displays total volume in gallons since last reset. If a meter is not used this display will be shown but 0 will be displayed.

PRESS ▼ FOR 3 SECONDS TO RESET TO 0.

#### User 5

Shows current time.

#### Setting Time of Day

Push NEXT until time of day screen is displayed. Press and hold ▼ until SET TIME is displayed and the hour flashes once. Press ▲ or ▼ until the correct hour is displayed.

Then press NEXT. The minutes will flash. Press ▲ or ▼ until the correct minute is displayed.

Press NEXT to return to the User Displays. Time of day should only need to be set after power outages lasting more than 8 hours, if the battery has been depleted and a power outage occurs, or when daylight saving time begins or ends. If a power outage lasting more than 8 hours occurs, the time of day will flash on and off which indicates the time of day should be reset. If a power outage lasts less than 8 hours and the time of day flashes on and off, the time of day should be reset and the battery replaced.

### Bypass Valve

The bypass valve is typically used to isolate the control valve from the plumbing system's water pressure in order to perform control valve repairs or maintenance. The WS1 bypass valve is particularly unique in the water treatment industry due to its versatility and state of the art design features. The 1" full flow bypass valve incorporates four positions, including a diagnostic position that allows service personal to work on a pressurized system while still providing untreated bypass water to the facility or residence. Its completely non-metallic, all-plastic design allows for easy access and serviceability without the need for tools.

The bypass body and rotors are glass filled Noryl<sup>3</sup> (or equivalent) and the nuts and caps are glass filled polypropylene. All seals are self-lubricating EPDM to help prevent valve seizing after long periods of non-use. Internal o-rings can easily be replaced if service is required.

The bypass consists of two interchangeable plug valves that are operated independently by red arrow-shaped handles. The handles identify the flow direction of the water. The plug valves enable the bypass valve to operate in four positions.

1. **Normal Operation Position:** The inlet and outlet handles point in the direction of flow indicated by the engraved arrows on the control valve. Water flows through the control valve during normal operation and this position also allows the control valve to isolate the media bed during the regeneration cycle. (See Figure 1)
2. **Bypass Position:** The inlet and outlet handles point to the center of the bypass, the control valve is isolated from the water pressure contained in the plumbing system. Untreated water is supplied to the plumbing system. (See Figure 2)
3. **Diagnostic Position:** The inlet handle points in the direction of flow and the outlet handle points to the center of bypass valve, system water pressure is allowed to the control valve and the plumbing system while not allowing water to exit from the control valve to the plumbing. (See Figure 3)
4. **Shut Off Position:** The inlet handle points to the center of the bypass valve and the outlet handle points in the direction of flow, the water is shut off to the plumbing system. If water is available on the outlet side of the softener it is an indication of water bypass around the system (i.e. a plumbing connection somewhere in the building bypasses the system). (See Figure 4)

---

<sup>3</sup> Noryl is a trademark of General Electric.

# BYPASS VALVE OPERATION

Figure 1

## NORMAL OPERATION

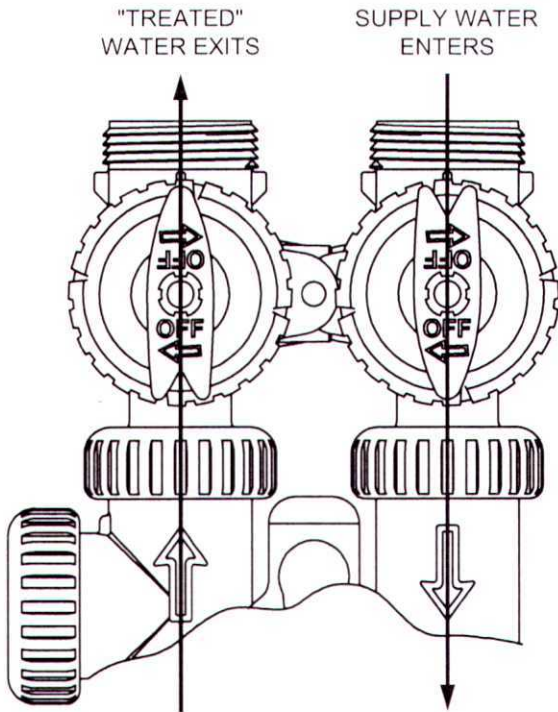

Figure 2

## BYPASS OPERATION

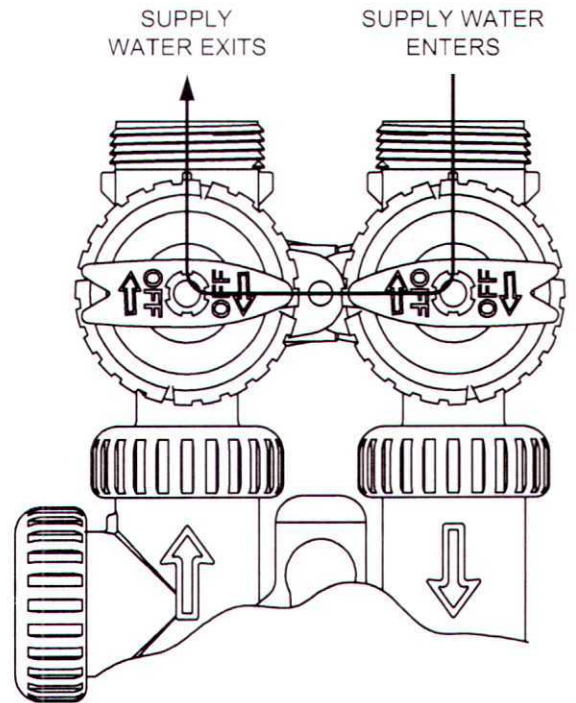

Figure 3

## DIAGNOSTIC MODE

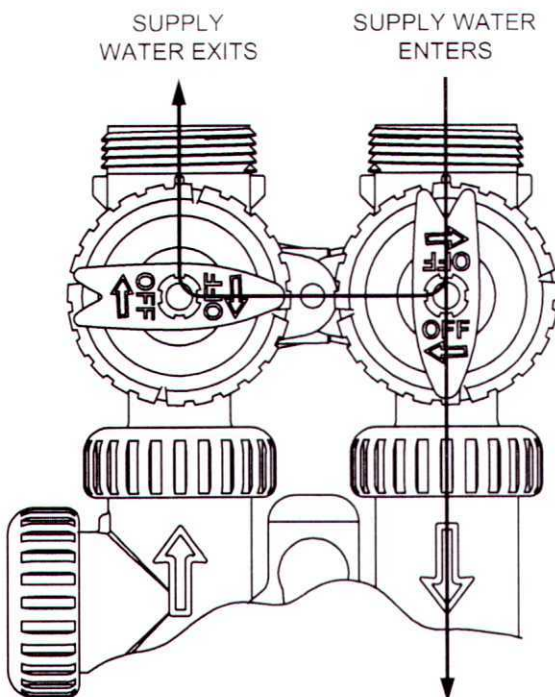

Figure 4

## SHUT OFF MODE

